

WASSERMANN TECHNOLOGIE GmbH

Bürgermeister-Ebert-Straße 5 / 36124 Eichenzell
T +49 (0)6659 82-0 / F +49 (0)6659 4198

Contact

System production: Stefan Krönung (s.kroenung@wassermann-technologie.de)
Automation: Sebastian Auth (s.auth@wassermann-technologie.de)

www.wassermann-technologie.de

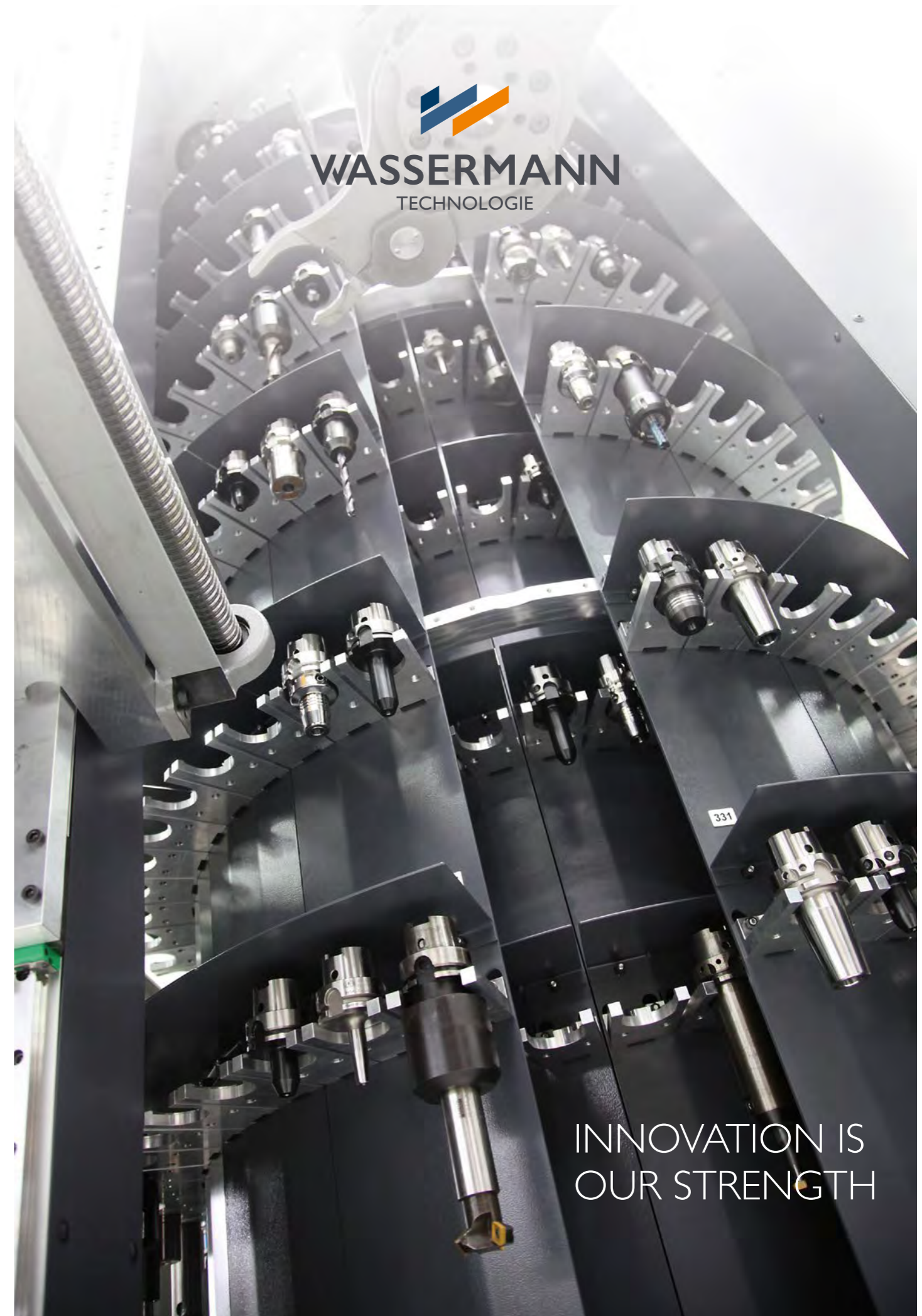

DISCOVER THE PRODUCT DIVERSITY OF WASSERMANN TECHNOLOGIE

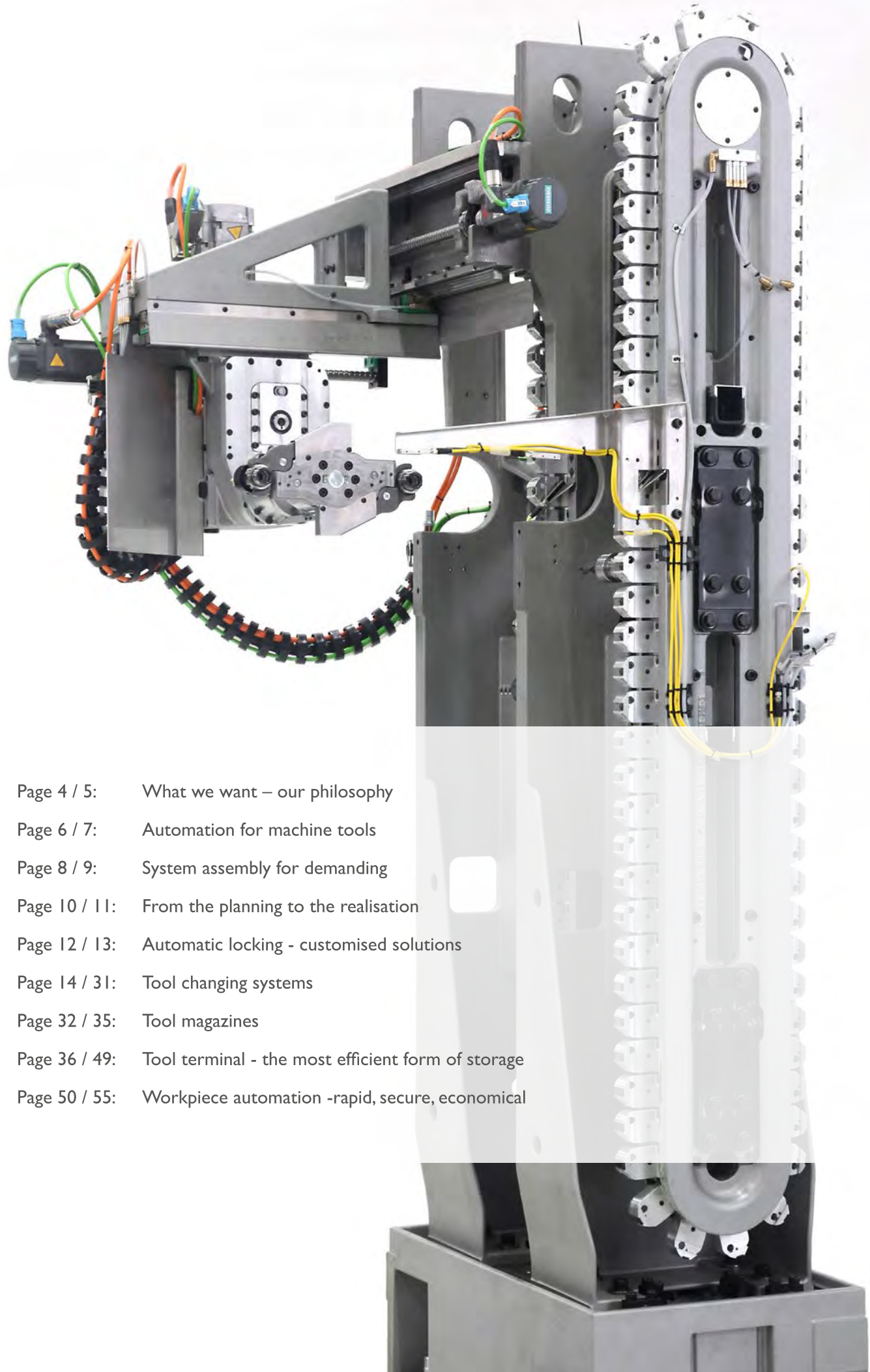
- 
- Page 4 / 5: What we want – our philosophy
 - Page 6 / 7: Automation for machine tools
 - Page 8 / 9: System assembly for demanding
 - Page 10 / 11: From the planning to the realisation
 - Page 12 / 13: Automatic locking - customised solutions
 - Page 14 / 31: Tool changing systems
 - Page 32 / 35: Tool magazines
 - Page 36 / 49: Tool terminal - the most efficient form of storage
 - Page 50 / 55: Workpiece automation -rapid, secure, economical



WE WANT MORE.

We at WASSERMANN TECHNOLOGIE want to achieve more – to achieve more for you with our expertise in system manufacturing and automation!

System manufacturing refers to demanding components and modules, which we produce for you as a cooperation partner. Specialising in selected industries with high quality requirements, we accompany you from the development work through to the series maturity of the final system. We have become well known and have constantly grown with this task. The next steps will involve opening up further product areas through synergy effects. For this reason, we have also had ourselves certified for the aerospace industry, among other things, in order to contribute our expertise in this area and facilitate the desired growth targets.

For us automation means the development and manufacturing of customised and high quality systems for tool and workpiece

handling in, and on, tooling machines. Having established ourselves in the field of system manufacturing, we now supply a large number of well-known German and international manufacturers with our products. Our latest development, the tool terminal, ensures an almost unlimited number of tools can be stored and managed within the smallest spaces directly at the tooling machine. This is our contribution towards smart and lean production.

All our actions are accompanied by three basic principles: innovation, sustainability and partnership. We do not just view ourselves as a supplier, we also want to be your partner.

Allow us to give wings to your ideas. Put us to the test! Demand more!

Sebastian Wassermann
Geschäftsführer

Eberhard Hahl
Geschäftsführer

AUTOMATION FOR TOOLING MACHINES

CUSTOMISED CONCEPTS AS OUR TRADEMARK

With the growth of demanding machining tasks and manufacturing processes the number of tools required for the production work generally also increases too. Many tooling machine manufacturers rely on the WASSERMANN TECHNOLOGIE'S expertise, starting with the development work and extending to the manufacturing operations.

In addition to basic components our trademark services also include customised automation solutions for tool and workpiece handling. We rapidly and flexibly respond to customer wishes and configure tailor-made solutions thanks to the flexible module system we employ. A lot of core components, such as the drive system or the gripper system, are produced exclusively at the company's own factory. We guarantee quality, availability and rapid response times.

Now some 800 systems leave our factory per year. Also following this, a variety of after-sales services are available to our customers once a contract has been concluded, whether this be in terms of spare part availability within 24 hours or worldwide maintenance and repair services.

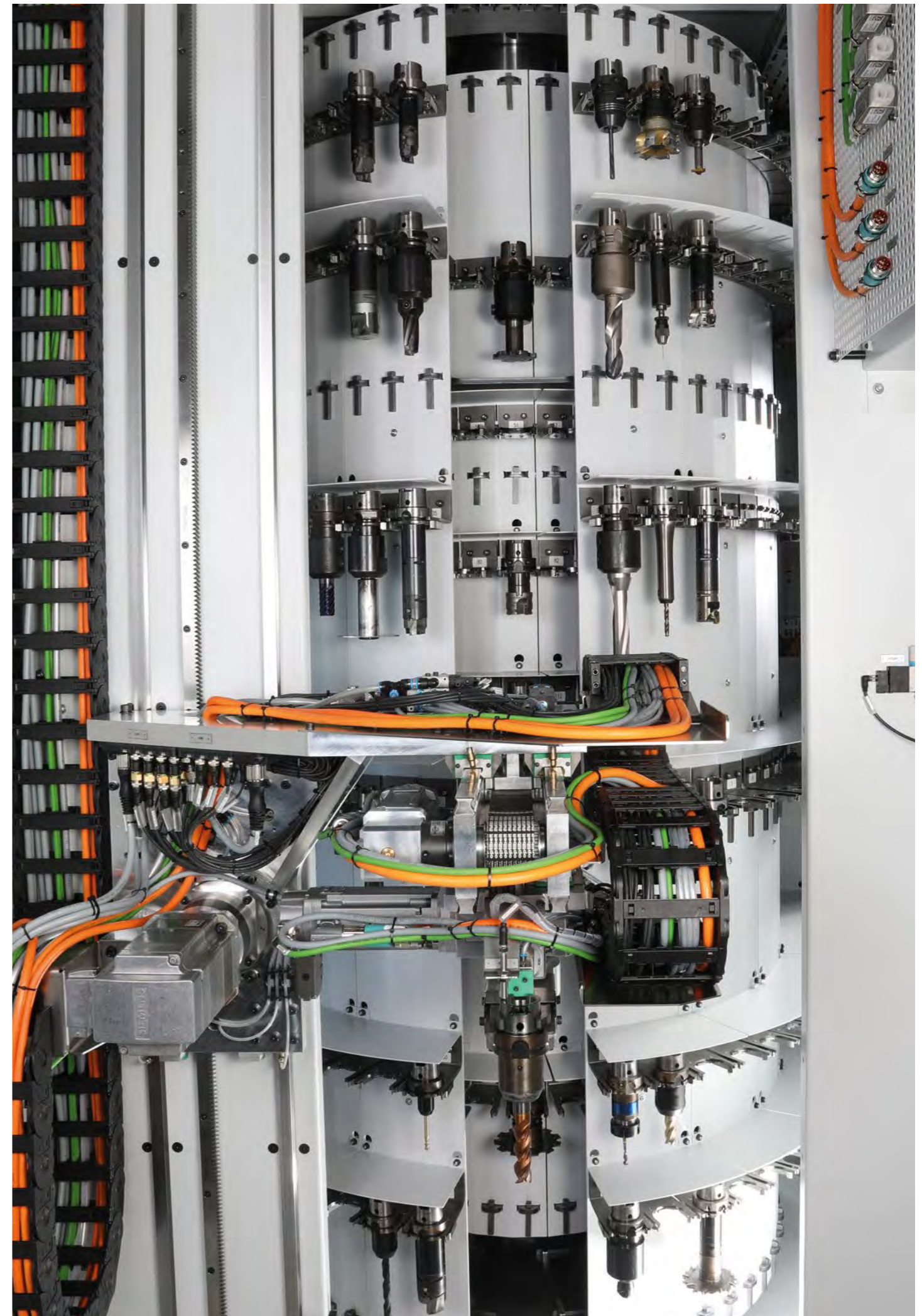

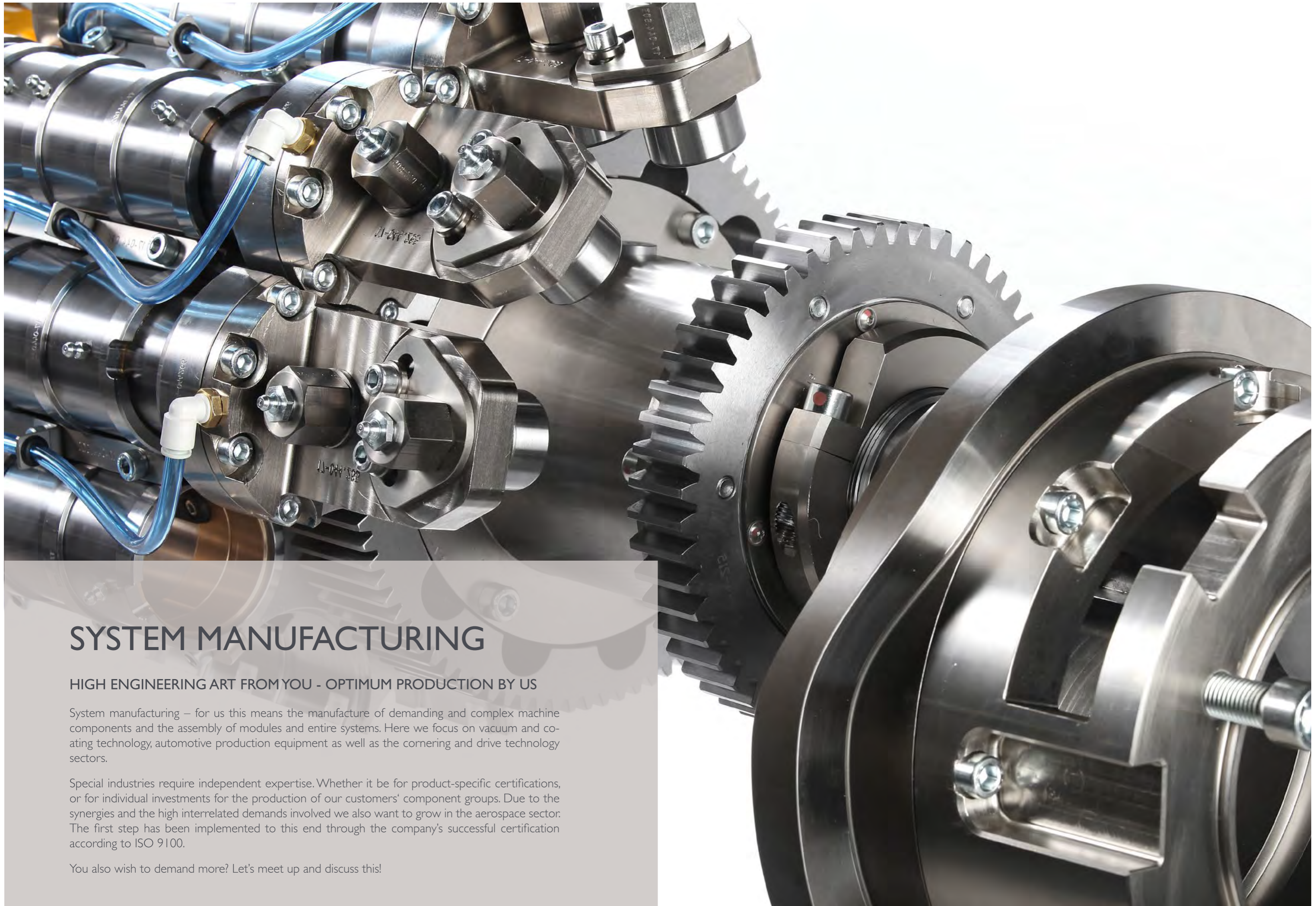

SYSTEM MANUFACTURING

HIGH ENGINEERING ART FROM YOU - OPTIMUM PRODUCTION BY US

System manufacturing – for us this means the manufacture of demanding and complex machine components and the assembly of modules and entire systems. Here we focus on vacuum and coating technology, automotive production equipment as well as the cornering and drive technology sectors.

Special industries require independent expertise. Whether it be for product-specific certifications, or for individual investments for the production of our customers' component groups. Due to the synergies and the high interrelated demands involved we also want to grow in the aerospace sector. The first step has been implemented to this end through the company's successful certification according to ISO 9100.

You also wish to demand more? Let's meet up and discuss this!

FROM THE PLANNING TO THE REALISATION

...Complete service packages from A to Z offer our customers special levels of convenience. The tool changers and magazines, which are precisely tailored to the customer's individual requirements, are a distinctive hallmark of WASSERMANN TECHNOLOGIE. Here too our tried and tested modular system accelerates the development phase.

WASSERMANN TECHNOLOGIE views one of its core tasks as the precise adaptation of tool changing and storage systems to the respective production requirements of the individual client. We happily take on the complete development and design work – which obviously always takes place in close coordination, with the customer, without unnecessary friction losses. The advantage for our customers: You can concentrate upon your core tasks in the process chain in a targeted manner

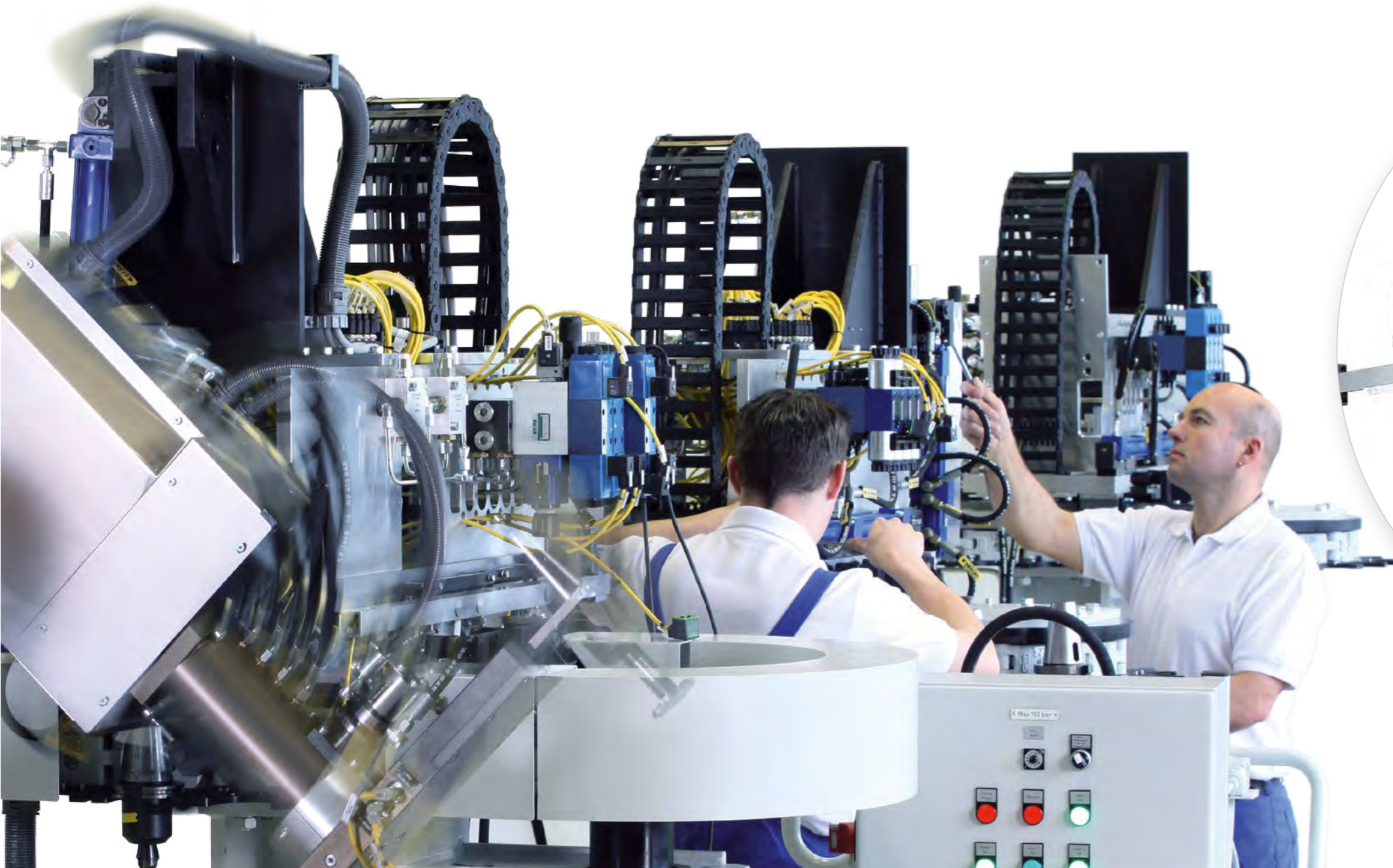

Tool changing systems for turning centres, turning / milling centres, portal milling machines extending to grinding centres.

TAILOR-MADE SOLUTIONS ARE OUR TRADEMARK

... in line with the increase in sophisticated machining tasks and manufacturing processes, the number of tools required for production usually increases as well. More and more manufacturers and renowned industrial companies are placing their trust in the expertise of WASSERMANN TECHNOLOGIE here.

In addition to basic components, our trademarks are also customised automation solutions for tool handling. Thanks to the modular design, we can respond quickly and flexibly to customer wishes and configure tailor-made solutions. Due to the expertise of our mechanical engineering specialists, we guarantee quality in addition to fast, reliable and quiet motion sequences.

Our cam-controlled tool changers with automatic locking are a guarantor of the highest process safety on tool delivery.

Tool changers with basic locking have a large disadvantage: During changes - especially of heavy tools with high tilting moments- the spindle tension is released first. Only then is the stroke and at the same time the locking of the gripper arm performed. This moment of instability also entails the risk that the tool would tilt and depart from its precise position.

To avoid this we rely on cam-controlled locking. In this case the tools are secured in a clamped state and still before a stroke motion thus ensuring failure-free tool changing. The precise cam control system prevents locking collisions onto the working spindle and thus has a positive effect upon their service lives.

Clamping gripper:

- /// a direct replacement of the tools between the spindle and the magazine is possible (without handling between the tool changer and the tool magazine)
- /// this is achieved through a cam-controlled, gripper-dependent locking mechanism
- /// it enables separate opening of the spindle-side gripper, whilst the magazine-side gripper is closed

Hook gripper:

- /// cam-controlled locking device
- /// no contact between the latch head and the tool when it swivels into place, thus no strain is placed on the spindle (no demands placed on the setting of the position control)

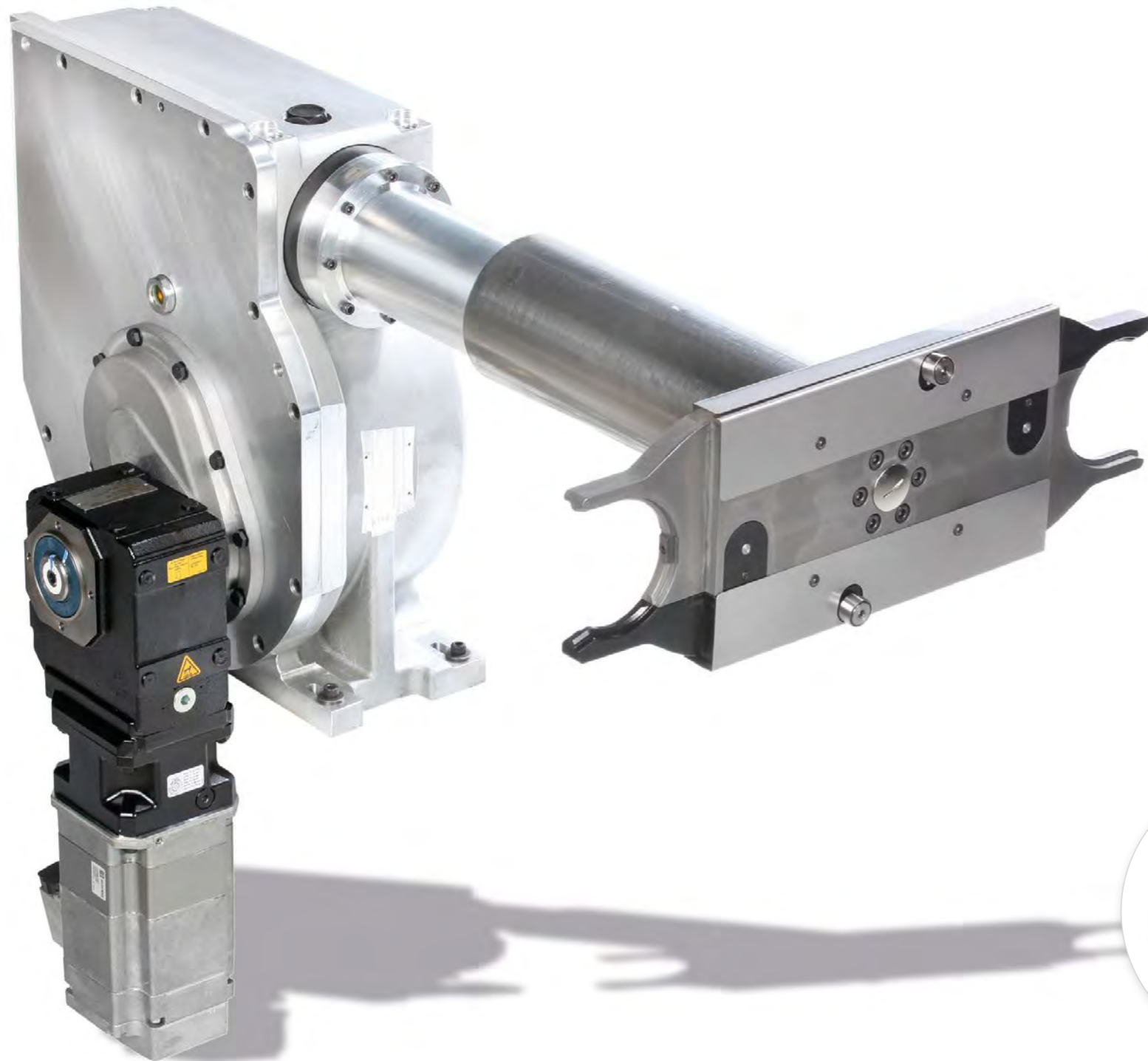

Regardless of whether you need our basic changer or a customised solution - our module system facilitates a rapid reaction to your requirements.



During the swivelling into place - the latch is retracted



Swivelled into place - before locking



Swivelled into place and locked - Latch clamps the tool

TOOL CHANGING SYSTEMS

MK 140 / 0112

Magazine; chain; spacing 140 mm; design type 0112

Product name	MK 140 / 0112
Spacing (Tool spacing) (mm)	140
Tool holders	All the standard tool holders
Alignment of the tool axis in the magazine	vertical
Number of tool pockets	60/80
Tool tilting torque (Nm)	-
Tool weight (kg)	max. 35
chain speed (m/min)	max. 10 m/min



Typ 0112



MK 75 / 0175

Magazine; chain; spacing 75 mm; design type 0175

Product name	MK 75 / 0175
Spacing (tool spacing) (mm)	75
Tool holders	all the standard tool holders
Alignment of the tool axis in the magazine	horizontal
Number of tool pockets	70 + 70
Tool tilting torque (Nm)	10
Tool weight (kg)	max. 10
chain speed (m/min)	max. 75 m/min

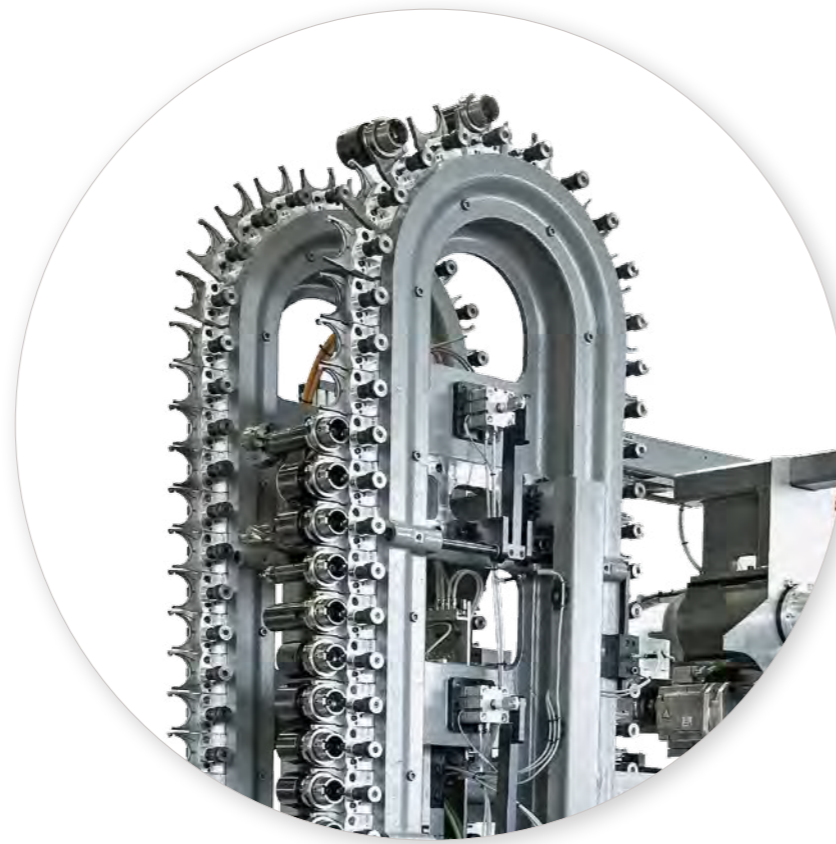

Typ 0175

MK 55 / 75 / 0252

Magazine; chain; spacing 55/75 mm; design type 0252

Product name	MK 55 / 75 / 0252
Spacing (tool spacing) (mm)	55 / 75
Tool holders	all standard tool holders
Alignment of the tool axis in the magazine	horizontal
Number of tool pockets	70 / 140 / 50 / 100
Tool tilting torque (Nm)	-
Tool weight (kg)	3 / 5
chain speed (m/min)	70 m/min

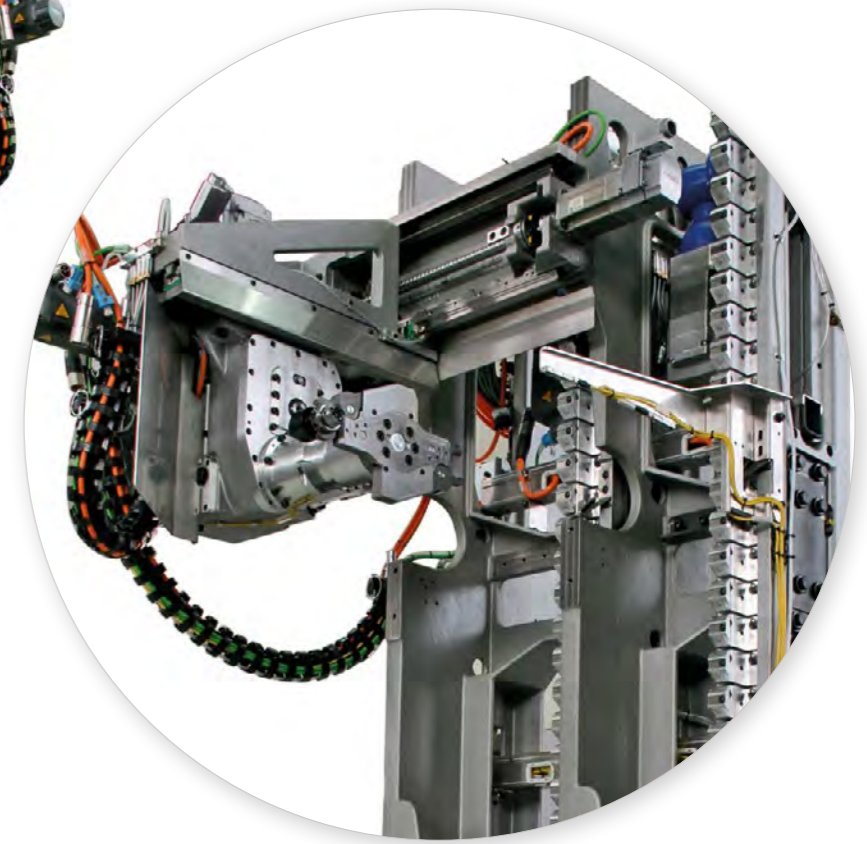
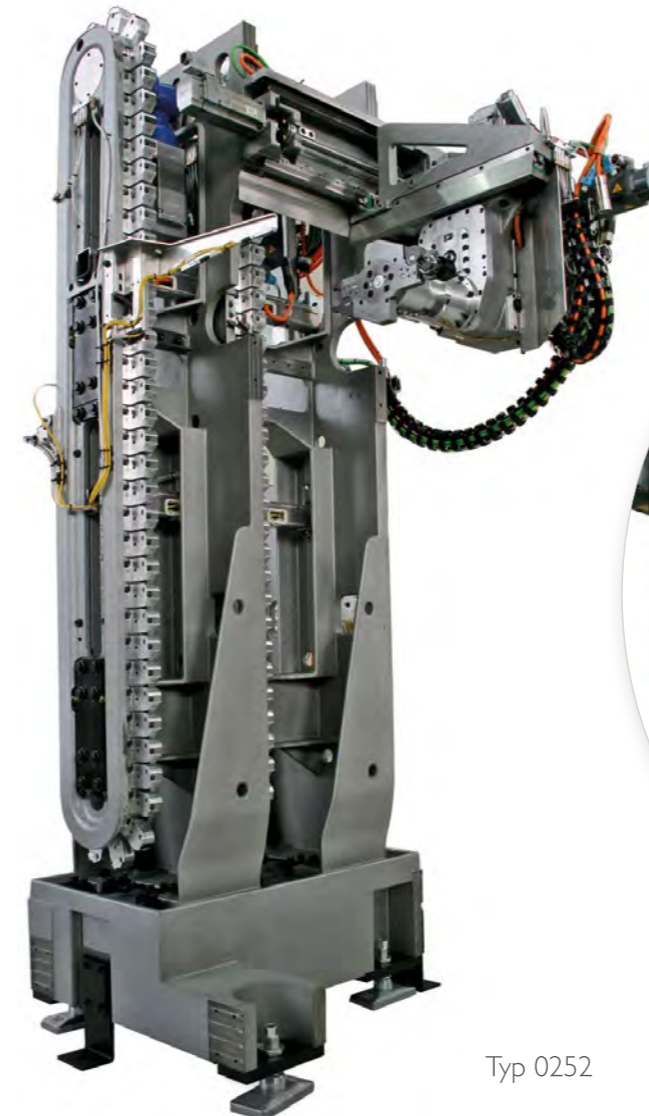

Typ 0252

MK 168 / 0261

Magazine; chain; spacing 75 mm; design type 0175

Product name	MK 168 / 0261
Spacing (tool spacing) (mm)	168
Tool holders	all standard tool holders
Alignment of the tool axis in the magazine	vertikal
Number of tool pockets	24 / 40
Tool tilting torque (Nm)	-
Tool weight (kg)	max. 35
Chain speed (m/min)	18 U/min

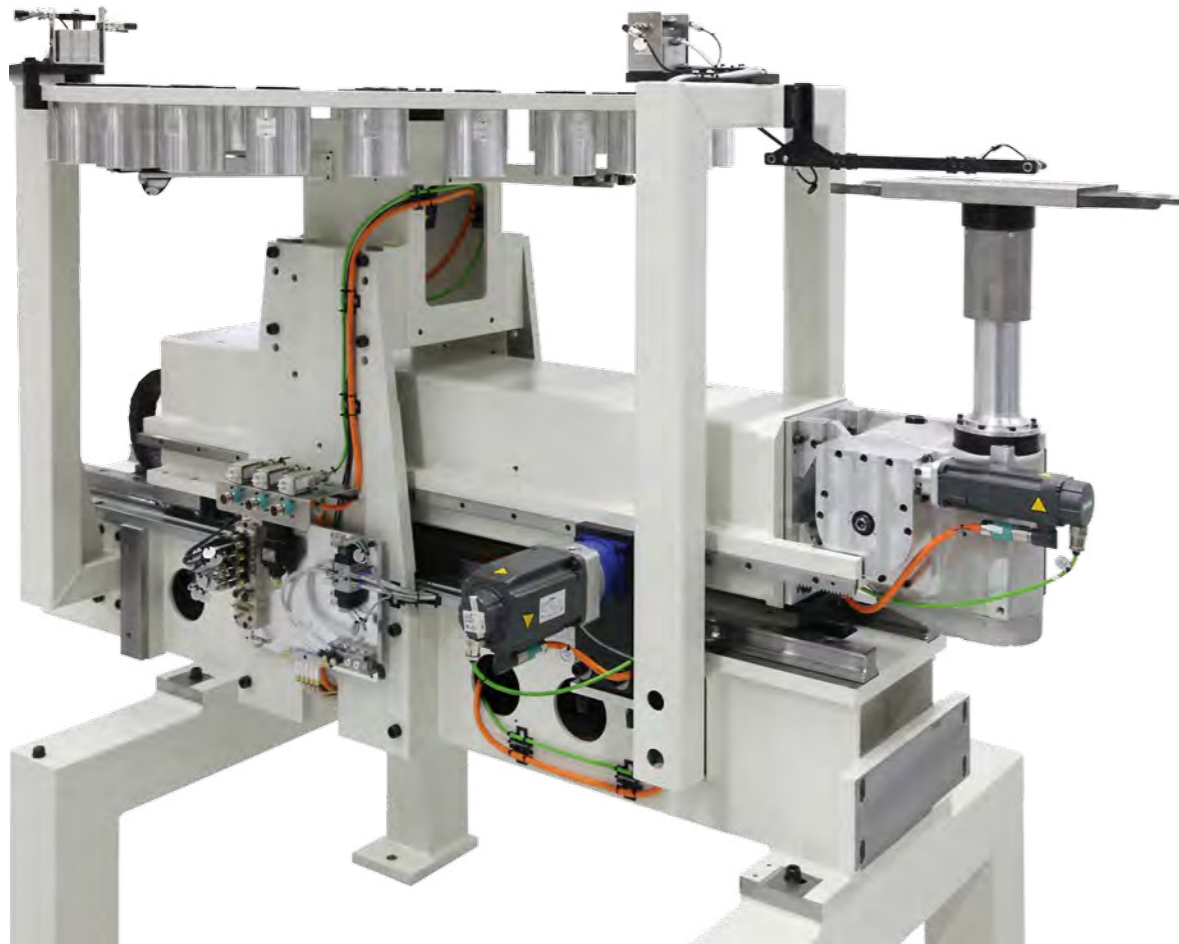

Typ 0261
Including servo axis for tool changer.

MK 115 / 0259

Magazine; chain; spacing 55/75 mm; design type 0252

Product name	MK 115 / 0259
Spacing (tool spacing) (mm)	115
Tool holders	all standard tool holders
Alignment of the tool axis in the magazine	circulating
Number of tool pockets	80 + 5
Tool tilting torque (Nm)	15
Tool weight (kg)	max. 25
Chain speed (m/min)	max. 35 m/min



Typ 0259
Including telescopic arm for tool changer.

MK 75 / 0205

Magazine; chain; spacing 75 mm; design type 0205

Product name	MK 75 / 0205
Spacing (tool spacing) (mm)	75
Tool holders	all standard tool holders
Alignment of the tool axis in the magazine	vertikal
Number of tool pockets	50 / 68
Tool tilting torque (Nm)	-
Tool weight (kg)	8
Chain speed (m/min)	max. 40 m/min
Chain speed (m/min)	

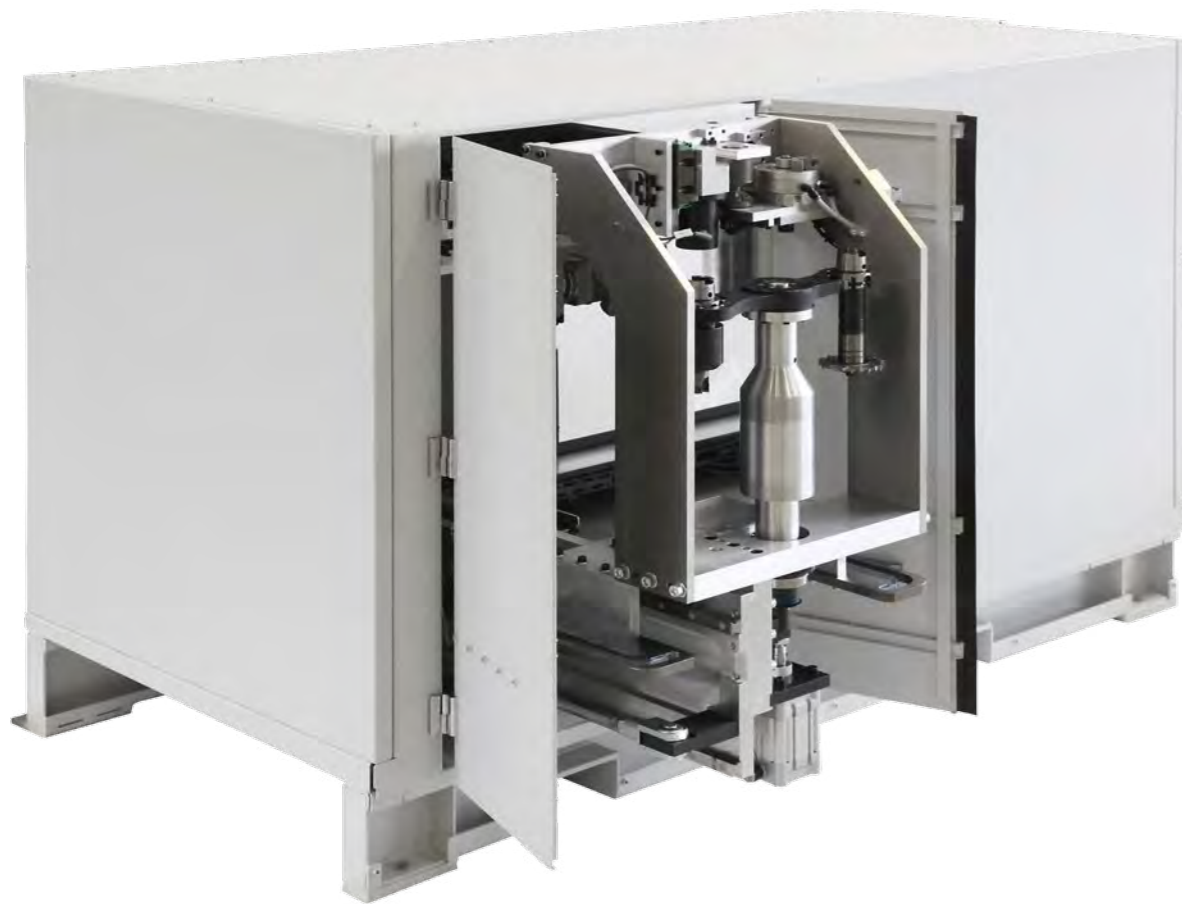

Typ 0205

MK 85 / 0264

Magazine; chain; spacing 85 mm; design type 0264

Product name	MK 85 / 0264
Spacing (tool spacing) (mm)	85
Tool holders	all standard tool holders
Alignment of the tool axis in the magazine	circulating
Number of tool pockets	12
Tool tilting torque (Nm)	2
Tool weight (kg)	3
Chain speed (m/min)	max. 20 m/min
Chain speed (m/min)	

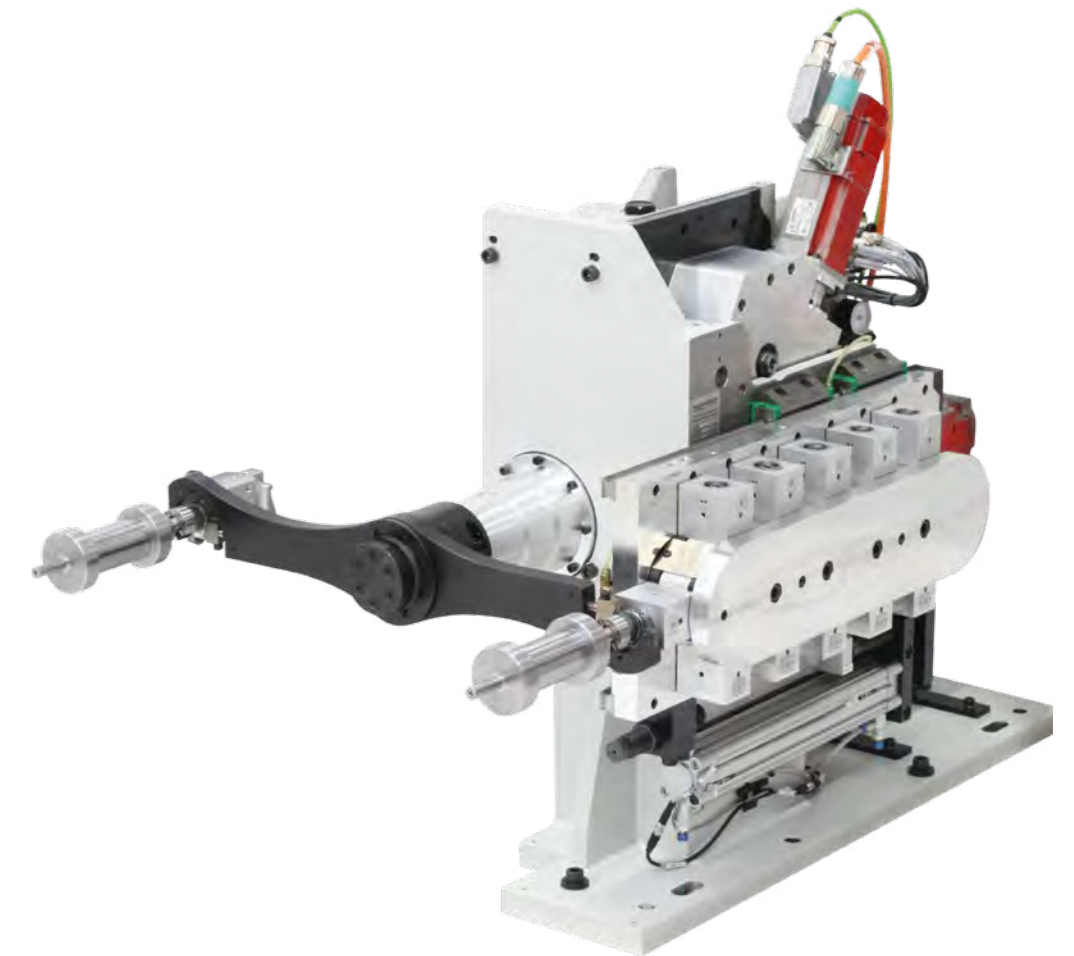

Typ 0264

MK 0324

Magazine; chain; spacing 465 mm; for grinding discs, design type 0252

Product name	MK 0324
Spacing (tool spacing) (mm)	465
Tool holders	Customised – agreed on based on HSK 100
Alignment of the tool axis in the magazine	horizontal
Number of tool pockets	20
Tool tilting torque (Nm)	60
Tool weight (kg)	50
Chain speed (m/min)	20 m/min
Tool diameter	400 mm
Tool length (mm)	270

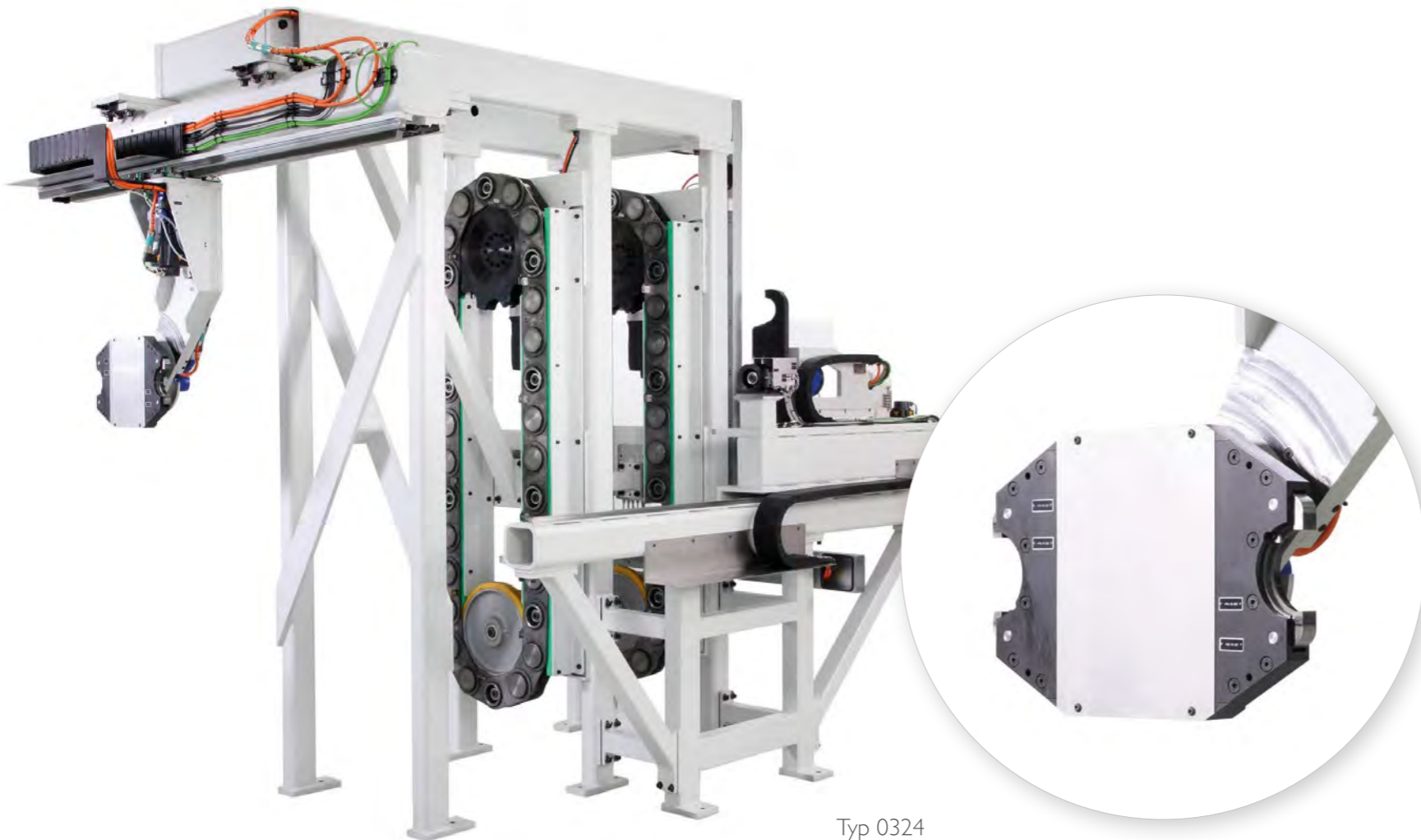

Typ 0324

MK 0324

Magazine; chain; spacing 480 mm; for grinding discs and truing rolls, design type 0324

Product name	MK 0324
Spacing (tool spacing) (mm)	480
Tool holders	Customised - agreed on based on HSK 80 für Grinding discs Customised - agreed on based on HSK 40 for truing rolls
Alignment of the tool axis in the magazine	horizontal
Number of tool pockets	HSK 80 - 25 HSK 40 - 8
Tool tilting torque (Nm)	60
Tool weight (kg)	40
Chain speed (m/min)	20 m/min
Tool diameter	406 mm
Tool length (mm)	200

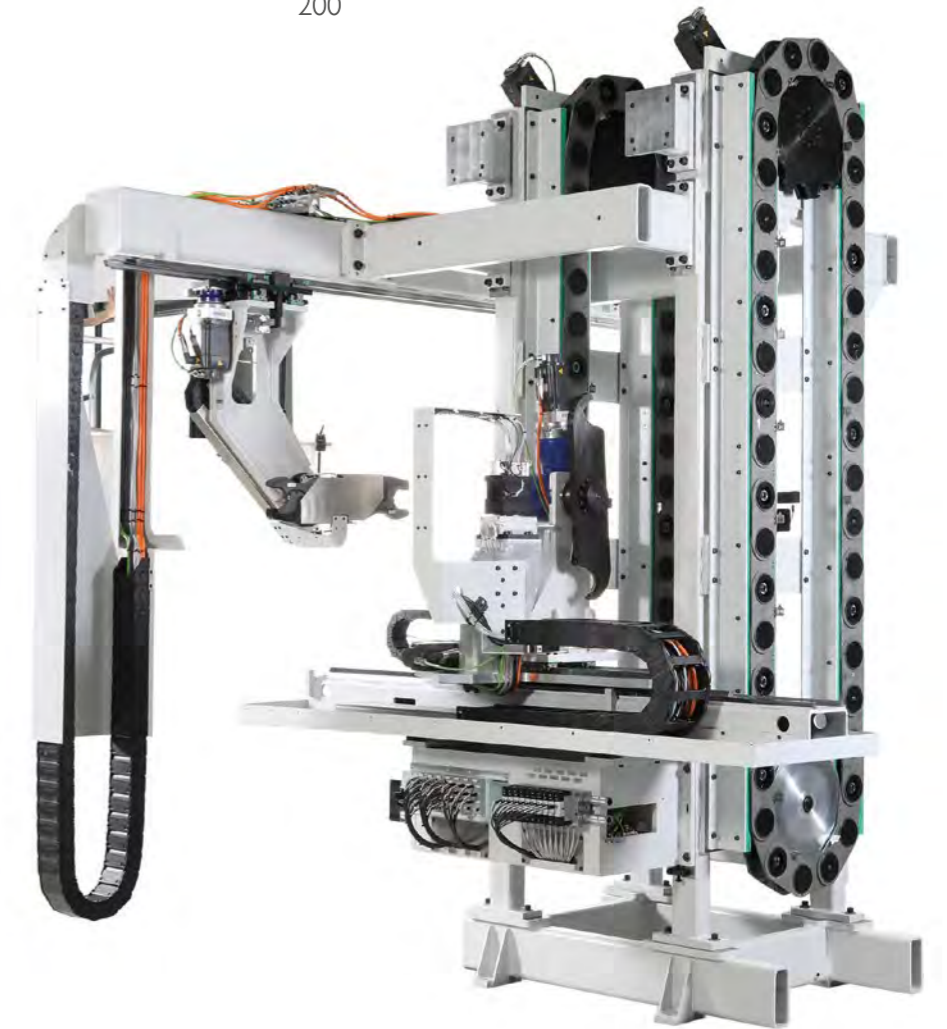

ERG 115 S

Flat roller star transmission, centre distance 110 mm

Installation position (Alignment of the tool axis)	Freely configurable
Tool holders	all standard tool holders
Tool mass (m)	3 kg
max. tool length	Full change: 200 mm
max. tool diameter	Ø 50 mm
max. tool diameter	up to 15 Nm (depending on the tool holder)
Swing diameter	260 mm
Change time (eg) = f (m, W, stroke)	0.75 s (Type 0252: m= 3 kg / W = 350 mm / stroke = 35 mm)
Weight of tool changer	approx. 60 kg
Drive	0,8 kW
Gripper arm	Gripper Clamping gripper



Typ 0252

ERG 125 S

Flat roller star transmission, centre distance 125 mm

Installation position (Alignment of the tool axis)	Freely configurable
Tool holders	all standard tool holders
Tool mass (m)	15 kg
max. tool length	Full change: 400 mm / Simple change: > 400 mm
max. tool diameter	Full change: diameter 200 mm / Simple change: diameter 120 mm
max. tool diameter	25 Nm (depending on the tool holder)
Swing diameter	350 mm (Typ 0206)
Change time (eg) = f (m, W, stroke)	0.6 s (Type 0206: m= 6 kg / W = 350 mm / stroke = 50 mm) 1.0 s (Type 0206: m = 15 kg / W = 350 mm / stroke = 102 mm)
Weight tool changer	approx. 100 kg
Drive	1,5 kW
Gripper arm	Gripper Clamping gripper



Typ 0269



Typ 0206

ERG 125 K

Flat roller star transmission, centre distance 125 mm

Installation position (Alignment of the tool axis)	Freely configurable
Tool holders	all standard tool holders
Tool mass (m)	15 k
max. tool length	any length
max. tool diameter	Diameter 200 mm
max. tool diameter	up to 25 Nm (depending on the tool holder)
Swing diameter	440 mm
Change time (e.g.)=f(m),W,stroke)	1,0 s (Typ 0238: m= 6 kg / B = 440 mm / Hub = 50 mm) 1,6 s (Typ 0238: m = 15 kg / B = 440 mm / Hub = 102 mm)
Weight of tool changer	approx. 60 kg
Drive	0,8 kW
Gripper arm	Gripper Clamping gripper



Typ 0238

RRG 160 S

Flat roller star transmission, centre distance 160 mm

Installation position (Alignment of the tool axis)	Freely configurable (Type 0175; 0264; 0271; Type 0222; 0261)
Tool holders	all standard tool holders
Tool holders	30 kg
max. tool length	Typ 0175: Full change: 370 mm / Simple change: > 370 mm Typ 0222: Full change: 340 mm
max. tool diameter	Full change: dia. 200 mm / Simple change: dia. 120 mm
max. tool diameter	up to 10 Nm (depending on the tool holder) Ø 120
Swing diameter	290 mm (Typ 0222) / 330 mm (Typ 0175) / 480 mm (Typ 0261) / 580 mm (Typ 0264)
Change time (eg) = f (m,W, stroke)	0,9 s (Typ 0264 - m = 3 kg / B = 580 mm / H = 38 mm) 0,9 s (Typ 0175 - m = 5 kg / B = 330 mm / H = 110 mm) 0,9 s (Typ 0222 - m = 10 kg / B = 290 mm / H = 50 mm) 3,5 s (Typ 0261 - m = 30 kg / B = 480 mm / H = 55 mm)
Weight of tool changer	approx 100 kg
Drive	1,0 kW; three-phase motor



Typ 0175

Typ 0206

Typ 0264

Typ 0271

Typ 0222

RRG 160 K

Spatial roller star transmission; centre distance 160 mm; Tool cone points in the direction of the transmission; type 0307

Installation position (Alignment of the tool axis)	horizontal (Typ 0307)
Tool holders	all standard tool holders
Tool mass (m)	12 k
max. tool length	any length
max. tool diameter	Ø 390 mm
max. tool diameter	15 Nm (depending on the tool holder)
Swing diameter	550 mm
Change time (e.g.)=f(m,W,stroke)	0,8s (m = 6 kg / B = 550 mm / HSK63)
Weight of tool changer	approx. 90 kg
Drive	1,5 kW
Gripper arm	Hook gripper



Typ 0307

RRG 220 S

Spatial roller star transmission; centre distance 200 mm;

Installation position (Alignment of the tool axis)	horizontal (Typ 0166; 0226)	vertikal (Typ 0217)
Tool holders	all standard tool holders	
Tool holders	35 kg (Typ 0166) / 25 kg (Typ 0226)	
max. tool length	Typ 0166: Vollwechsel: 470 mm (HSK; PSC; KM) / Einfachwechsel: > 470 mm Typ 0226: 550 mm	
max. tool diameter	Type 0166 full change: dia 280 mm / simple change : dia 200 mm Type 0226: dia 140 mm	
max. tool diameter	70 Nm (depending on the tool holder)	
Swing diameter	480 mm (Typ 0166; 0217) / 380 mm (Typ 0226)	
Change time (eg) = f (m,W, stroke)	0,85 s (Typ 0166 - m = 6 kg / B = 480 mm / H = 85 mm) 1,9 s (Typ 0166 - m = 35 kg / B = 480 mm / H = 155 mm) 1,2 s (Typ 0226 - m = 15 kg / B = 380 mm / H = 80 mm) 2,0 s (Typ 0217 - m = 35 kg / B = 480 mm / H = 55 mm)	
Weight of tool changer	approx. 200 kg	
Drive	1,5 kW	
Gripper arm	Gripper Clamping gripper (Typ 0166; 0217); Hook gripper (Typ 0226)	



Typ 0166

Typ 0217

Typ 0226

RRG 200 K

Flat roller star transmission, centre distance 200 mm

Installation position	horizontal
Tool holders (H 0 120 mm)	all standard tool holders
Tool mass (m)	35 kg
max. tool length	any length
max. tool diameter	Typ 0133: Ø 400 mm (B = 568 mm)
max. tool diameter	160 Nm (depending on the tool holder)
Swing diameter	Typ 0133: 568 - 970 mm
Change time (e.g.)=f(m),W, stroke)	1,0 s (m= 6 kg / B = 680 mm / H = 120 mm) 4 s (m = 30 kg / B = 970 mm / H = 155 mm)
Weight of tool changer	approx. 260 kg
Drive	0,75 kW
Gripper arm	Hook gripper



Typ 0133

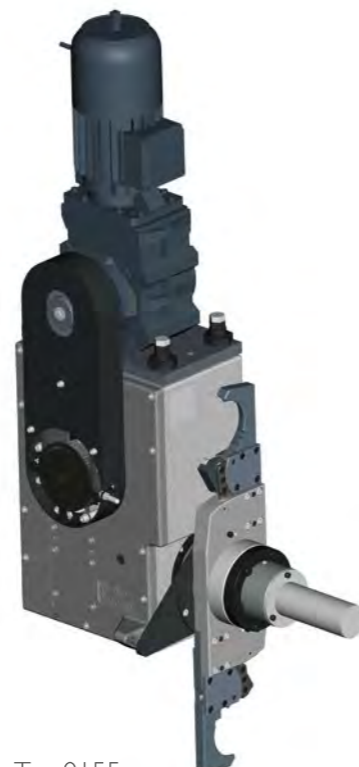

Typ 0155

RRG 240 S

Ebenes Rollensterngetriebe; Achsabstand 240 mm

Installation position	horizontal (Typ 0279; 0286)
Tool holders	all standard tool holders
Tool mass (m)	50 kg
max. tool length	Full change: 660 mm (HSK 63-125; PSC 63-80X; KM 63-100) / Simple change: > 660 mm
max. tool diameter	Typ 0279: Full change: dia. 620 mm / Simple change: dia. 320 mm Typ 0286: Full change: dia. 400 mm / Simple change: dia. 320 mm
max. tool diameter	bis 70 Nm (depending on gripper arm and tool holder)
Swing diameter	880 mm (Typ 0279) / 650 (Typ 0286)
Change time (eg) = f (m,W, stroke)	Typ 0279: 1,3 s (m = 6 kg / B = 880 mm / H = 70 mm) Typ 0286: 1,6 s (m = 10 kg / B = 650 mm / H = 85 mm)
Weight of tool changer	approx. 370 kg
Drive	2,3 kW
Gripper arm	Hook gripper (Typ 0286); Gripper Clamping gripper (Typ 0279)



Typ 0279



Typ 0286

TOOL MAGAZINES

MS 128 / 0278

Magazine; disc; spacing 128 mm; design type 0278

Product name	MS 128 / 0278
Tool holders	all standard tools
Alignment of the tool axis in the magazine	horizontal
Number of tool pockets	20
Tool weight (kg)	8
Disc speed (rpm)	30 l/min

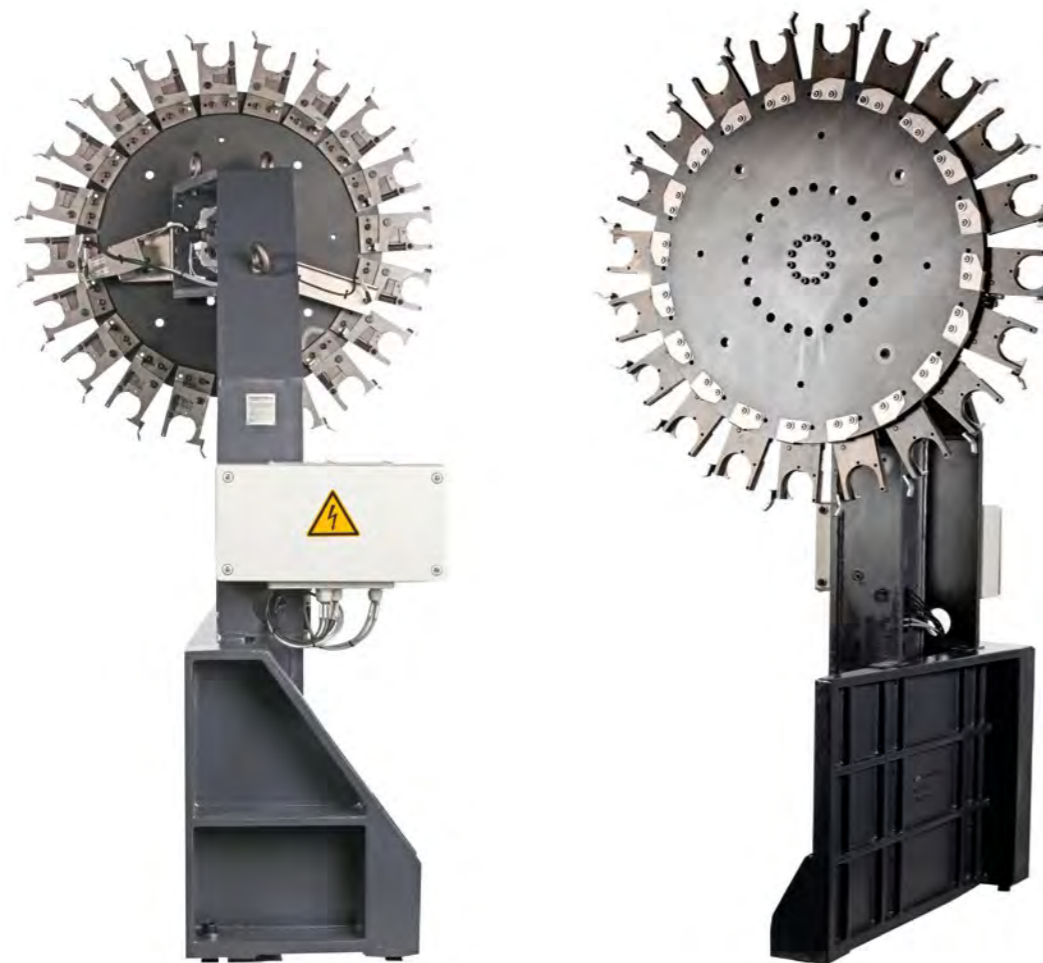

Typ 0278

RRG 240 S

Magazine; chain; spacing 85 mm; design type 0316

Product name	MK 85 / 0264
Spacing	Dependent on tool
Tool holders	all standard tool holders
Alignment of the tool axis in the magazine	horizontal
Number of tool pockets	80
Tool tilting torque (Nm)	2
Tool weight (kg)	25
Chain speed (m/min)	20 m/min

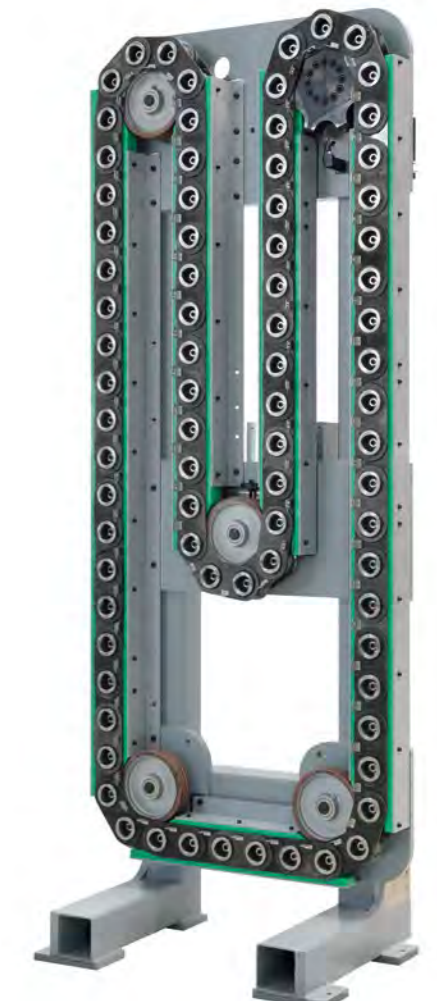
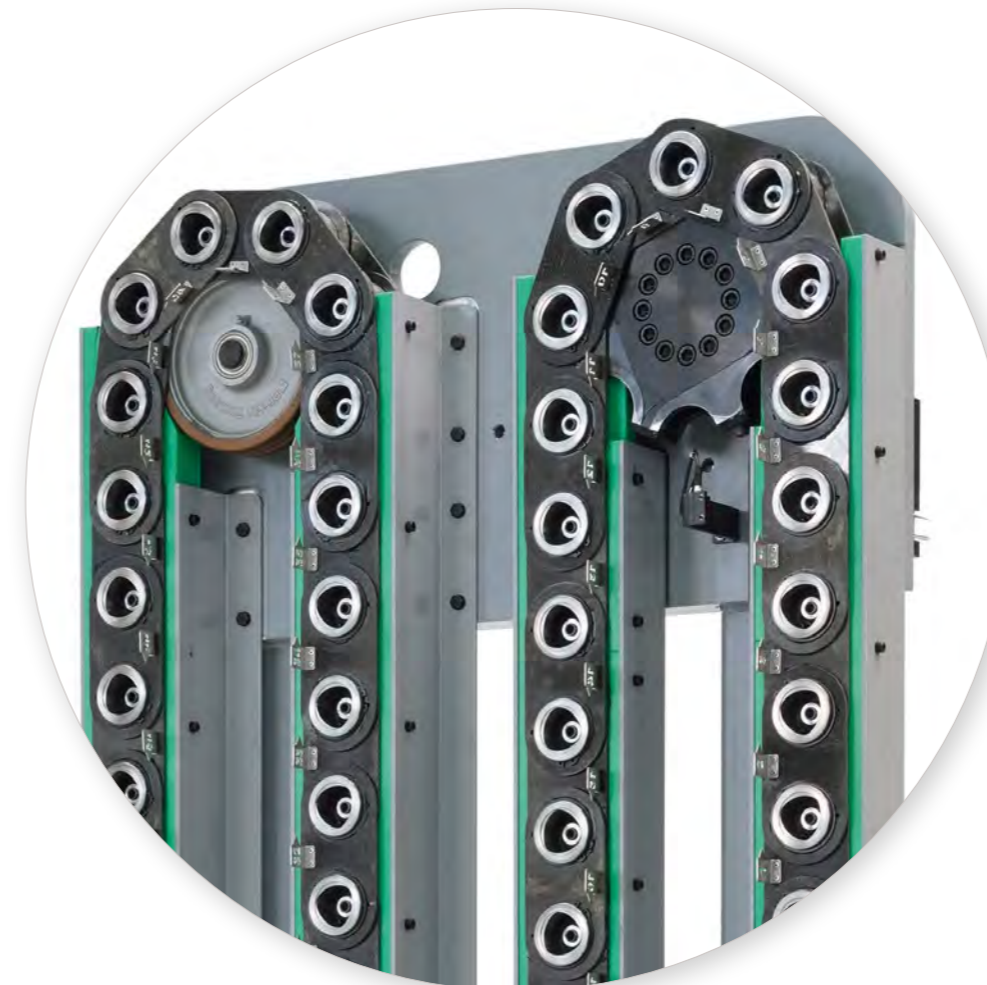

Typ 0316

MK 140 / 120 / 0323

Pickup magazine; chain; spacing 140/120 mm; design type 0323

Product name	MK 140 / 120 / 0323
Spacing (tool spacing) (mm)	140 mm, optional 120
Tool holders	all standard tool holders
Alignment of the tool axis in the magazine	horizontal
Number of tool pockets	72 / 120
Tool tilting torque (Nm)	-
Tool weight (kg)	20
Chain speed (m/min)	40 m/min



Typ 0323

THE TOOL TERMINAL IS THE MOST EFFICIENT TYPE OF STORAGE

...THE LATEST INNOVATION PRODUCED BY WASSERMANN IS THE TOOL TERMINAL: WITH ITS COMPACT DESIGN, IT FACILITATES THE HIGHEST TOOL DENSITY.

The demand for tools also increases in line with the increase in the requirements in the machining sector. In addition, all the aspects relating to flexibility and productivity are becoming increasingly important. WASSERMANN TECHNOLOGIE takes up this topic and responds to the current customer requirements with the new tool terminal.

By means of drums being combined within one another, the terminal achieves an extremely high density of tools. The tools are handled using a linear unit with an integrated tool changer. This takes care of the placement of the tools in the drums as well as their introduction into a tool buffer or directly into a machine-side tool changer.

The tool and drum diameters of the different construction sizes are stipulated. The tool length, length division, number of tools, tool cleaning, tool mountings and tool data acquisition via RFID (Balluff) are freely configurable. The tool terminal thus proves itself to be an extremely flexible system. It can be supplied in all standard tool mountings and is available to the customer with one, two or three drums as required.

As a full-service provider WASSERMANN TECHNOLOGIE is also available to you for the tool change in the machine room and the spindles. With our wide range of tool changing systems, we can cover almost every requirement.

The highlights and advantages:

- /// High tool density
- /// Tool management of up to 9000 tools
- /// Can be combined with numerous tool changers
- /// Can be combined with industry robots
- /// Minimal space requirements
- /// Intelligent design – the highest levels of quality
- /// Rapid amortisation
- /// Low maintenance

Can be used as:

- /// Direct magazine
- /// Tool magazine for tool management
- /// Extension of existing tool magazines
- /// Supply magazine for several machine tools

The intelligent supplementary magazine has the following capabilities:

- /// Tool management
- /// Database
- /// Sequence control
- /// Interface to the machine tool
- /// Software for additional external handling
- /// Interface to peripheral devices
- /// Data acquisition of the tool data

USE IN LINE WITH THE CUSTOMER'S REQUIREMENTS

Overview of the tool terminal's application options

connected to machine tool	Additional magazine	<p>Without control system: The entire sequence is controlled by the machine controller.</p> <p>With sequence control and IO-Link interface: The tool management is performed by the machine controller; the tool handling in the additional magazine and the transfer to the machine's own magazine is performed by the sequence control of the additional magazine.</p> <p>Sequence controls offers own management and interface: Sequence controls offers own tool management and an interface to the machine tool control system for transferring the control signals and the tool-specific data. Optionally with integration of RFID or data transfer of the tool data from a tool presetting.</p>
	Direct magazine	<p>Without control system</p> <p>Control of the machine tool Tools are changed directly or via an intermediate handling into the spindle of the machine tool.</p>
	Supply or central magazine	<p>With sequence control, own administration and interface: With sequence control, own tool management and an interface to the various machine tool control systems for transferring the control signals and the tool-specific data. Optionally with integration of RFID or data transfer of the tool data from a tool presetting. The machine tool requests a tool and a handling system, controlled by the tool magazine, places it in the corresponding magazine of the machine tool.</p>
Freestanding	<p>Using RFID: The tool data are automatically read in by means of RFID and the tools are stored in a space optimised manner in the tool magazine according to their dimensions. Due to the reading in of the data typing errors are prevented during manual entry ensuring high levels of data security. A precise space allocation during loading is not necessary here and it is therefore a very smooth process.</p> <p>With connection to a tool presetting device: The tool data are automatically written into the database of the terminal via the interface to the tool presetting device. Manual entry is also not required here. During loading the tools must, however, be inserted on an insertion position specified by the control system.</p> <p>With integration into a tool management system</p>	

A VARIABLE CONCEPT

FOR MACHINE OPERATORS, MACHINE MANUFACTURERS AND AUTOMATORS

For you as a machine operator, the terminal offers you a cost-effective way to upgrade your machine. We also perform the system integration work in your companies.

As machine manufacturer, the terminal offers you a flexible option of equipping your machine with an up-to-date number of tools. We also cooperate closely with your design department and thus facilitate customised solutions.

For you as an automator, the terminal offers you the option of equipping entire manufacturing lines with tools due to its sophisticated control system. We also supply you with the suitable peripherals, such as transfer axes.

OVERVIEW OF THE ADVANTAGES

- /// The transshipments between the machine and the terminal run in parallel with the tooling time, while the clamping devices are retrofitted.
- /// Search times for tools are no longer required.
- /// Tool assembly times are markedly reduced
- /// The times for storage and provision of tools cease to apply
- /// Measuring times for re-measuring the tools are no longer required.
- /// An estimated saving per year of several thousand euros
- /// Not connected to the machine

WE ARE THE LEADING MANUFACTURER OF TOOL CHANGERS IN GERMANY.



370

371

372

373

374

375

78

79

80

331

332

333

334

335

336

DESIGNS OF THE TOOL TERMINAL

TAILORED TO THE CUSTOMER'S REQUIREMENTS

We at WASSERMANN TECHNOLOGIE want to offer you the most ideal solution and for this reason have developed two basic versions of the tool terminal.

- /// Tool terminal S-Curve with round rack magazine: Up to a maximum of 280 tool places
- /// Tool terminal D-Curve with drum magazine: Up to a maximum of 570 tool places, customised solutions permits many more tool places

Interesting options for you:

- /// Taper cleaning: Brush cleaning, optional immersion bath cleaning
- /// RFID: Balluff BIS M optionally BIS C
- /// Interfaces to peripheral devices: Tool presetters, machine tools, databases

Together with the customer, we develop a tool terminal that is ideally adapted to the conditions.

Round shelf medium HSK50/63 PSC 6, weight max 15kg

Number of tool places		
Tool length (mm)	Shelf 48, Dmax 160mm	Total
200	96	96
300	96	96
400	90	90
		282

Round shelf big HSK 100, weight max 35Kg

Number of tool places		
Tool length (mm)	Shelf 45, Dmax 280mm	Total
250	135	135
350	45	45
450	0	0
650	39	39
		219

TOOL TERMINAL S-MAGAZINE

CONFIGURATION EXAMPLES

Round shelf small HSK25 / 40 PSC 3/4, weight max 3kg

Number of tool places		
Tool length (mm)	Shelf 36, Dmax 120mm	Total
150	72	72
200	72	72
250	72	72
300	66	66
		282

Size	small	medium	large
Height/H (mm)	< 3000	< 3000	< 3000
Width/W (mm)	900	1600	2300
Depth/D (mm)	900	1600	2300

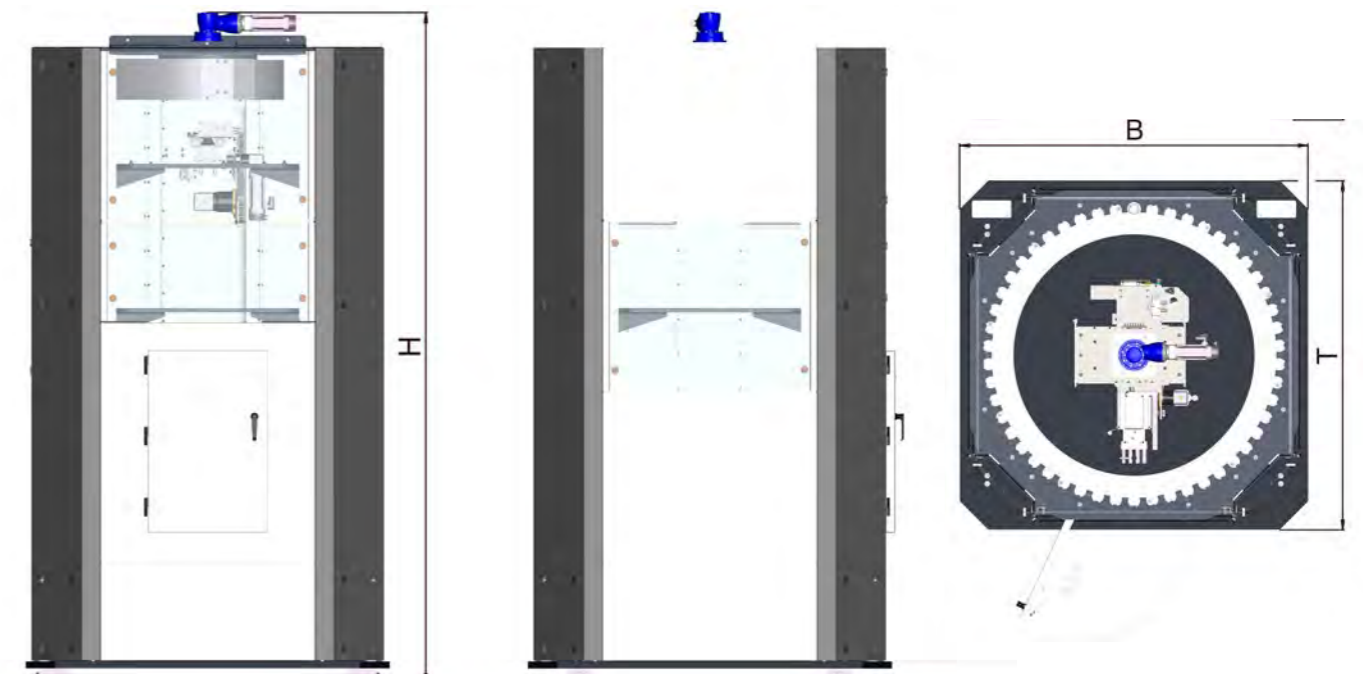

TOOL TERMINAL D-MAGAZINE

CONFIGURATION EXAMPLES

Single drum small HSK25 / 40 PSC 3 / 4, weight max 3Kg

Number of tool places		
Tool length (mm)	Outer drum 36, Dmax 120mm	Total
150	72	72
200	72	72
250	72	72
300	72	72
		288

Double drum large HSK 100, weight max 35Kg

Number of tool places			
Tool length (mm)	Outer drum 42, Dmax 280mm	Inner drum 30, Dmax 280mm	Total
250	126	0	126
350	42	60	102
450	0	60	60
650	42	0	42
			330

Triple drum middel HSK 50/63 PSC6, weight max 15kg

Number of tool places				
Tool length (mm)	Outer drum 45, Dmax 160mm	Middel drum 27, Dmax 120mm	Inner drum 24, Dmax 80mm	Total
200	90	54	48	192
300	90	108	48	246
400	90	0	24	114
				552

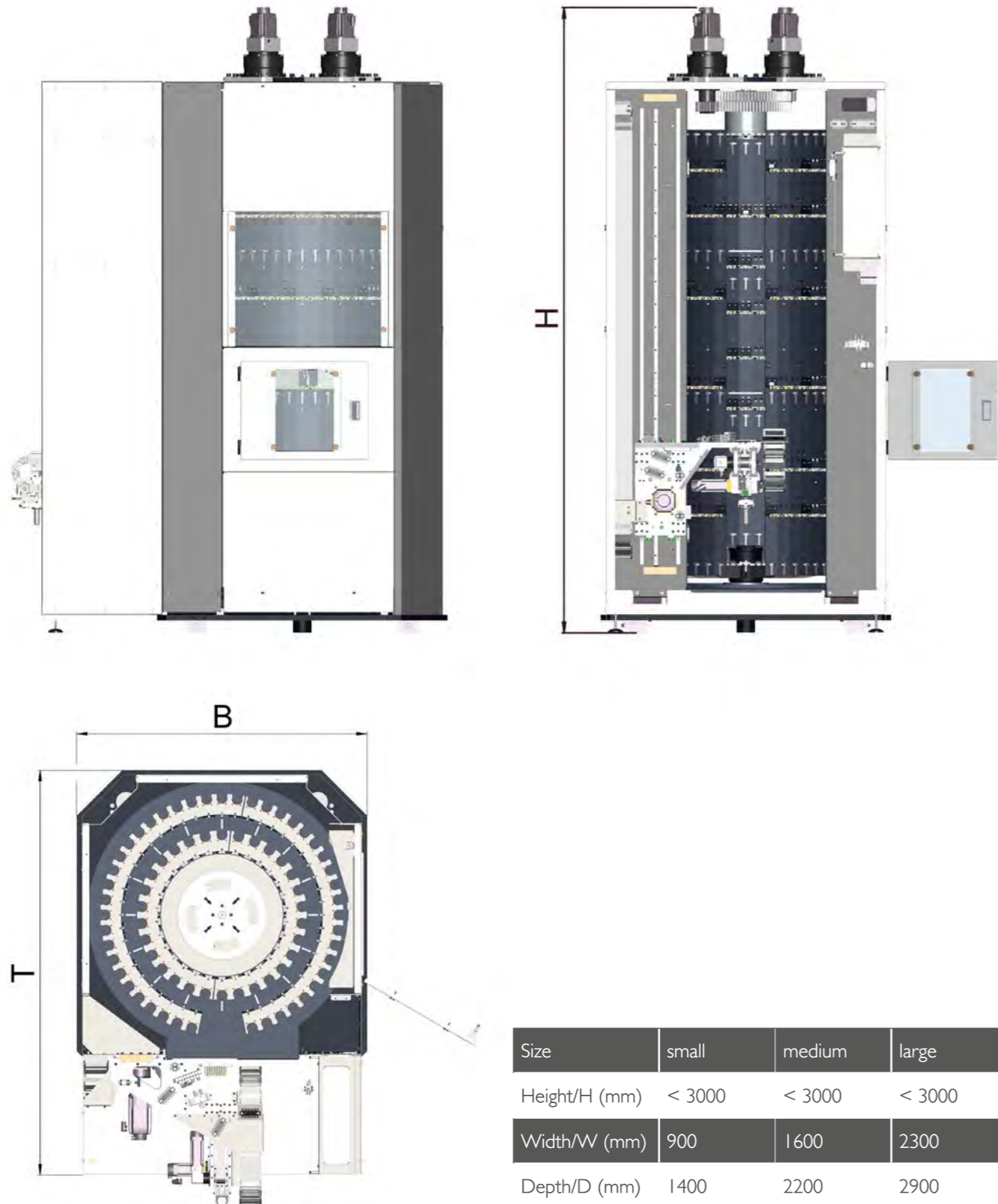

CONTROL SYSTEMS

The following controllers can be connected, Siemens:

Sinumerik 840D solution line (Milling Machine- und lathe) ab NC-Version 4.0	Sinumerik 840D operate (Milling Machine- und lathe) ab NC-Version 4.0
---	--

Heidenhain

Control	as of NC Version
TNC 128	771841-01
TNC 320	340551-03
TNC 320	340551-05, 771851-01
TNC 620	34056x-01, 73498x-01, 81760x-01
TNC 620	34056x-03
TNC 640	34059x-01
MANUALplus 620	548328-05
MANUALplus 620	54843x-01
CNC PILOT 620	688945-01
CNC PILOT 620	688945-02
CNC PILOT 640	688946-01, 688947-01
MillPlusIT V6x0	53895x-03, 73738x-01
GrindPlusIT	510060-04
GrindPlus 640	73502x-01
iTNC 530	340420-06, 340422-01, 340480-01
iTNC 530	34049x-03, 60642x-01

YOU WANT MORE FUNCTIONALITY? RETROFIT PROVIDES A REMEDY!

You want to use more functions for your existing machine tool for the automation tasks, but your control system does not yet facilitate this? As an alternative to our own interface you have the option, in combination with our pallet changer, of renewing your existing Heidenhain control system with the current generation of systems. This results in new functionalities for the automation of your machine tool.

Speak to us – we are happy to advise you!



BEEXAMPLE OF A TERMINAL CONNECTION

TOOL TERMINAL TO DMU



WORKPIECE AUTOMATION - RAPID, SECURE, ECONOMICAL

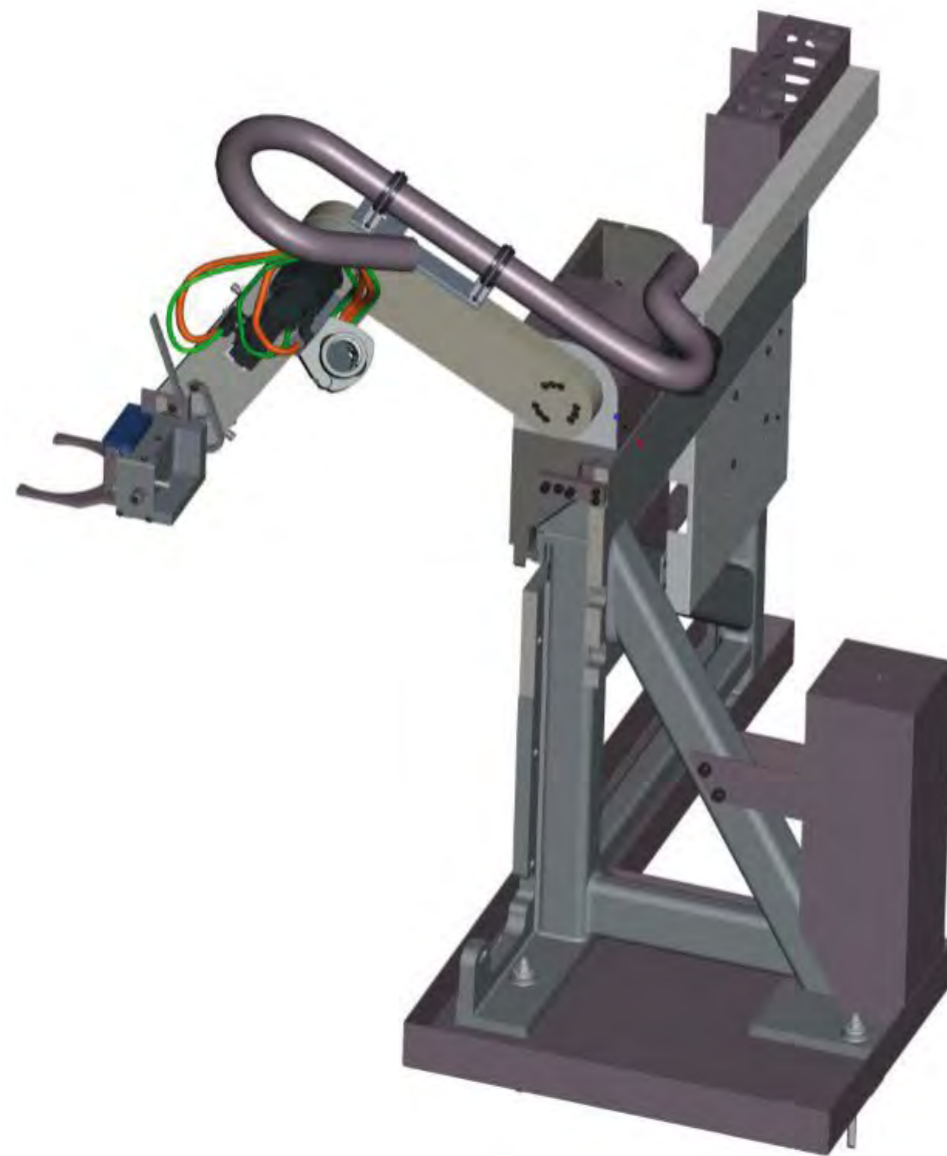

At a glance - example:

- /// Workpiece weight up to 20 kg
- /// Workpiece diameter up to 200 mm
- /// Workpiece length up to 400 mm
- /// Changing times of the cam-controlled workpiece changer up to 2x10 kg <1 s, up to 2 x 20 kg 1.5 s
- /// Travelling axis between the conveyor belt and the workpiece spindle
- /// Gripper according to workpiece shape for unmachined and finished parts

...We have also transferred the experience of WASSERMANN TECHNOLOGIE as a manufacturer of tool changers to the handling of workpieces and components. Rapid, secure and economical:

These are the outstanding features of our professional handling.

The sooner we are integrated in the planning and development process, the more efficient the result. This diversity and quality, which characterises the cooperation with WASSERMANN TECHNOLOGIE, finds expression in a large number of satisfied customers and partners.

At a glance:

- /// customised solutions for the handling of workpieces and components
- /// drive control according to customer requirements:
 - /// cam-controlled
 - /// hydraulisch
 - /// pneumatic
 - /// combined
- /// Rapid changing times
- /// servotechnology
- /// adapted grippers according to workpiece and component form
- /// Installation position according to requirements
- /// high workpiece weights



PALLET MAGAZINE ROUND SHELVES

CONFIGURATION EXAMPLES

Round shelving unit, medium size, pallet size 320x 320 x 40, total weight per pallet 150 kg

Level	Total height (Pallet + workpiece)	Number of pallet spaces
1	520	4
	380	1
2	520	4
	Handbeladung 520	1
3	520	5
		15

Round shelving unit, medium size, pallet size 320x 320 x 40, total weight per pallet 150 kg

Level	Total height (Pallet + workpiece)	Number of pallet spaces
1	350	6
2	350	5
3	300	4
4	550	5
		20

Round shelving unit, large, pallet size 500 x 500 x 50, total weight per pallet 150 kg

Level	Total height (pallet + workpiece)	Number of pallet spaces
1	510	4
	370	1
2	510	4
	Manual loading 510	1
3	510	5
		15

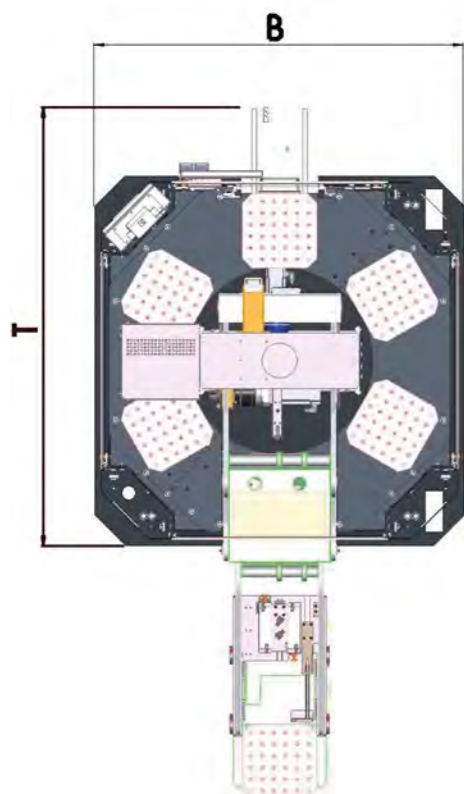
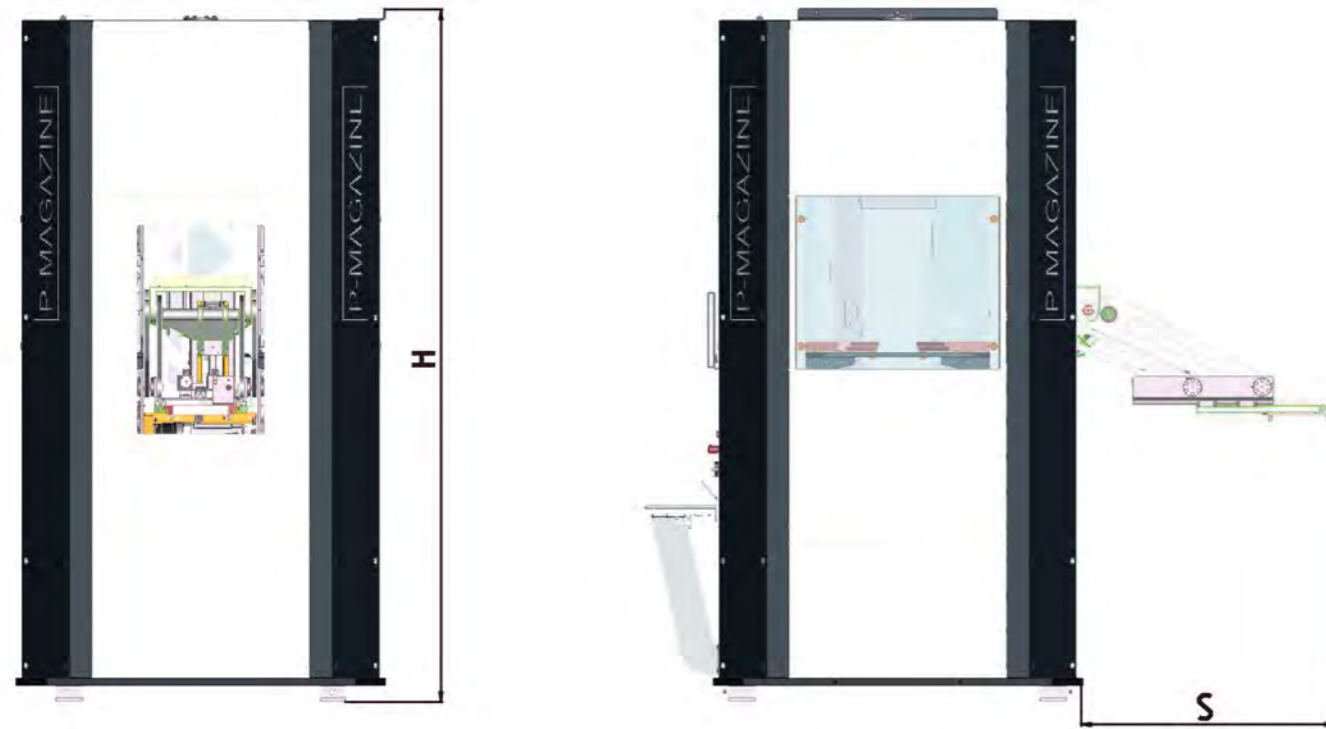

Pallet sizes

Sizes	Width/W	Length/L	Depth/D
Round magazine medium size	320	320	40
	250	250	40
Round shelving unit large	200	400	50
	400	400	50
	500	500	50

Round shelving unit pallet terminal P-magazin

Size		medium	large
Height/H		< 3000	< 3000
Width/W		1590	2100
Depth/D		1890	2400
Travel/S/S		1090/1365	1420/1695

PALLET STORAGE UNIT

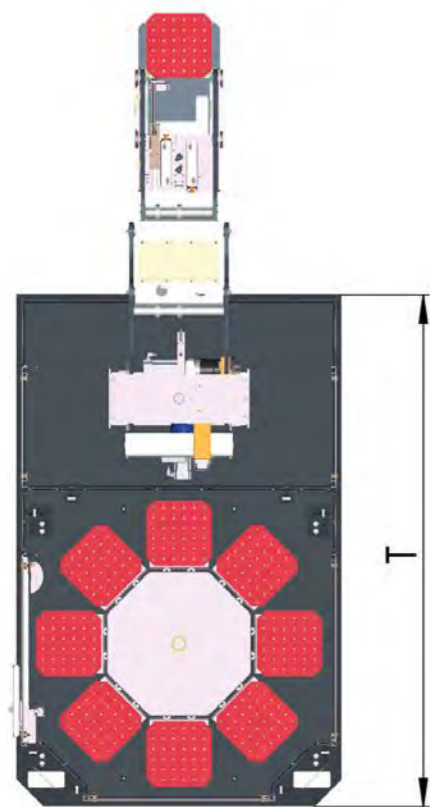
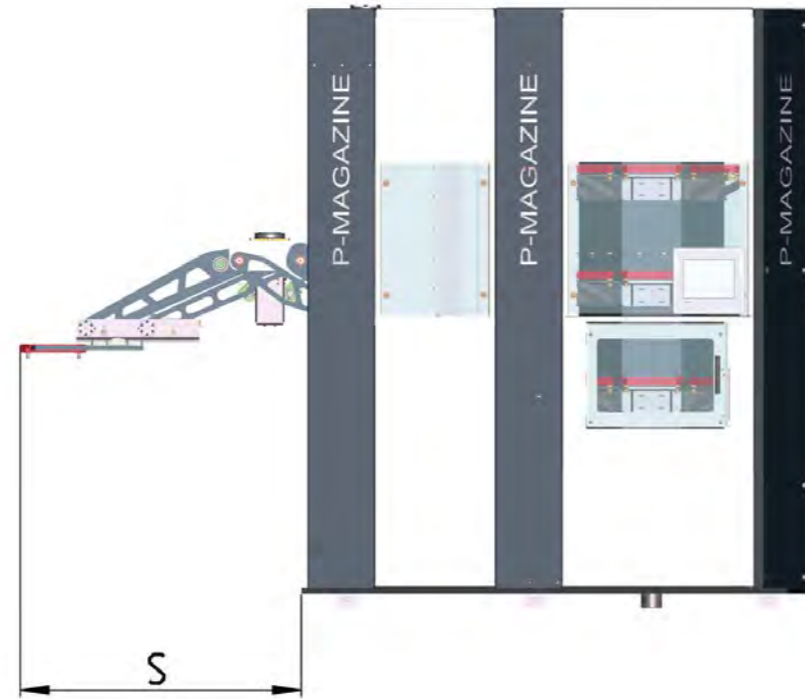
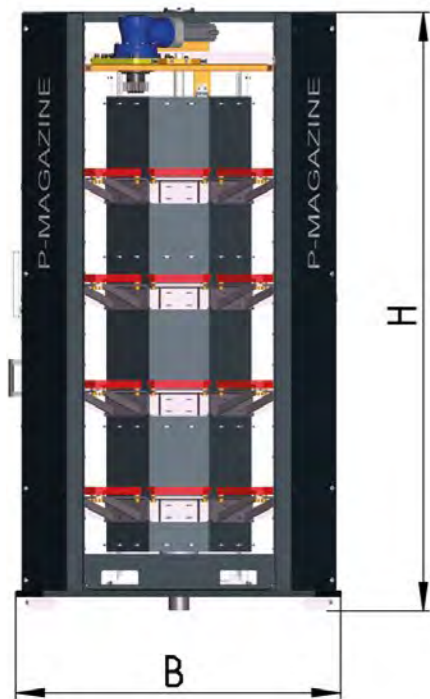

Size	medium
Height/H	< 3000
Width/W	1590
Depth/D	2500
Travel/S	1380/1655

CONFIGURATION EXAMPLES

Round shelving unit, medium size, pallet size 320x 320 x 40, total weight per pallet 150 kg

Level	Total height pallet + workpiece)	Number of pallet spaces
1	450	8
2	450	8
3	450	8
4	450	8
		32

Round shelving unit, medium size, pallet size 320x 320 x 40, total weight per pallet 150 kg

Level	Total height pallet + workpiece)	Number of pallet spaces
1	350	8
2	350	8
3	350	8
4	350	8
5	350	8
		40